

3M™ Water Filtration Products

SGLP-RO

Reverse Osmosis System

Applications: Combi-ovens, Flash steamers and Espresso

The 3M™ SGLP-RO Reverse Osmosis (RO) System is designed to produce consistent quality water for the reduction of scale and corrosion causing minerals in combi-oven, flash steamer and espresso applications¹. The RO membrane is designed to remove many of the minerals that cause scale build-up and corrosion. Activated carbon and graded porosity pre-treatment help protect the RO membrane from chlorine and fine particulate.

Product Benefits:

- Cartridge interconnect system allows for quick and easy cartridge change-outs. No spills, no mess.
- Integrated pump requires no power; operates on incoming water pressure².
- Sanitary Quick Change (SQC) encapsulated cartridges reduce contamination during change-outs.
- Rugged stainless steel bracket design is rust and corrosion resistant. Allows system to either be wall-mounted or set on a shelf.
- Compact design allows for installation in tight areas.
- NSF Certified to Standard 58.



Product Specifications:

Model #	Part #	Description	System Production	Application
SGLP-RO	5612304	Reverse Osmosis System	53.0 gpd (179.6 lpd)	Combi-ovens, Flash steamers, Espresso

¹ Carbon post filter is recommended when using SGLP-RO in espresso applications.

² Minimum 50 psi (344.7 kPa) feedwater pressure required.

3M™ Water Filtration Products

SGLP-RO

Specifications

- System incorporates reverse osmosis technology.
- System incorporates non-electric pump.
- System contains integrated pre-filtration for the reduction of particulate and chlorine taste and odor.
- RO membrane is a thin film composite (TFC) type.
- System is wall mountable with a stainless steel bracket design.
- System inlet plumbing connections are 1/4" quick disconnect type.
- System drain plumbing connections are 1/4" quick disconnect type.
- System outlet plumbing connections are 3/8" quick disconnect type.
- System includes an integrated 2 gallon (7.6 liter) water storage tank.
- System produces 53.0 gpd (179.6 lpd).
- System minimum incoming water pressure of 50 psi (345 kPa) & maximum of 100 psi (689 kPa) ± 15%.
- System minimum incoming water temperature of 40°F (4.4°C) and a maximum of 100°F (37.8°C).
- System incoming water pressure must be between 50 and 100 psig ± 15% or external pump is required.

Spec # _____

Quantity _____

Model # _____

Part # _____

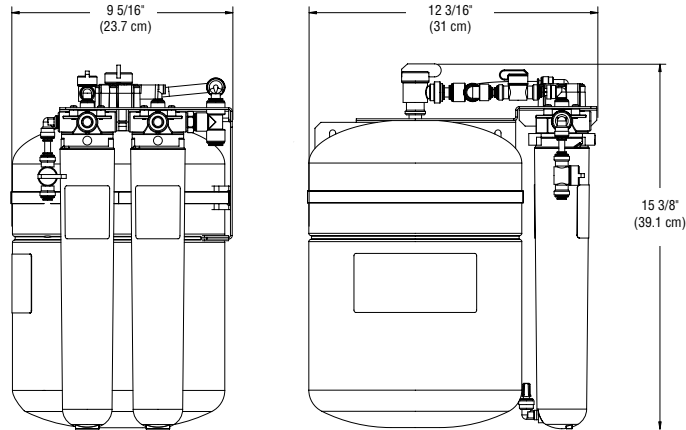

Important: Installation Tips

⚠ WARNING: Read entire manual. Failure to follow all guides and rules could cause personal injury or property damage.

- Check with your local public works department for plumbing codes. You must follow their guidelines as you install the Water Filtration system.
- Your Water Filtration system will withstand up to 100 pounds per square inch (psi) water pressure. If your water supply pressure is higher than 80 psi, install a pressure reducing valve before installing the Water Filtration system.

To reduce the risk associated with the ingestion of contaminants:

- DO NOT use with water that is microbiologically unsafe or of unknown quality without adequate disinfection before or after the system.

NOTICE: To reduce the risk associated with water leakage or flooding:

- Read and follow Use Instructions before installation and use of this system.
- Change the disposable PreFilter and RO Membrane at the recommended interval; the disposable PreFilter and RO Membrane MUST be replaced every 12 months or sooner.
- **Failure to replace the disposable PreFilter and RO Membrane at recommended intervals may lead to reduced filter performance and failure of the filter, causing property damage from water leakage or flooding.**

Replacement Cartridges

Part Number	Model Number	Type	Qty. Required
5598729	ScaleGard™ RO Membrane	Reverse Osmosis Membrane	1
5570613	ScaleGard™ PreFilter	5 Micron PreFilter Cartridge	1

Limited Warranty

Warranty, Limited Remedy, and Disclaimer: 3M warrants that each 3M product meets the applicable 3M product specification at the time 3M ships the product. 3M MAKES NO OTHER EXPRESS OR IMPLIED WARRANTIES OR CONDITIONS, INCLUDING ANY IMPLIED WARRANTY OR CONDITION OF MERCHANTABILITY OR FITNESS FOR A PARTICULAR PURPOSE. If a 3M product does not conform to this warranty, the sole and exclusive remedy is, at 3M's option, replacement of the 3M product or refund of the purchase price.

Limitation of Liability: Except for the limited remedy above, and except to the extent prohibited by law, 3M will not be liable for any loss or damage arising from or related to the 3M product, whether direct, indirect, special, incidental, or consequential, regardless of the legal or equitable theory asserted.



3M Purification Inc.
400 Research Parkway
Meriden, CT 06450 U.S.A.

Toll Free 1-866-990-9785
Worldwide 1-203-237-5541
Fax 1-203-238-8701
Web www.3Mfoodservice.com



System tested and certified by NSF International against NSF/ANSI Standard 58 and CSA B483.1 for the reduction of the claims specified on the Performance Data Sheet.

3M and ScaleGard are trademarks of 3M Company.
© 2017 3M Company. All rights reserved.
70020194059 REV 0917
Please recycle. Printed in U.S.A.