



EV9100-32

CB20-302E Water Filter

High flow, high capacity carbon filter for chlorine and chloramine reduction



CB20-302E System: EV9100-32

302 Replacement Cartridge Kit:
EV9105-21

Kit contains: (1) CC1E replacement cartridge
and (1) CC3E replacement cartridge

BENEFITS

Improves the taste and consistency of beverages and ice by reducing chloramine, chlorine and other off-tastes and odors

CC1E extended service cartridge contains radial flow granular activated carbon (GAC)

CC3E cartridge fine filters water by reducing sediment and dirt larger than 1/2 micron in size

Reduces asbestos fibers and cysts such as Cryptosporidium and Giardia

High pressure housing includes head with pressure relief valve, mounting bracket and bowl

Integral inlet and outlet pressure gauge monitors operation

INSTALLATION TIPS

Choose a mounting location which is suitable to support the full weight of the system when operating (60 lbs.)

3/4" FNPT inlet and outlet connection

Install on cold water lines only

Do not install where unit is exposed to direct sunlight

Allow a minimum of 4" clearance under the filter to facilitate cartridge change

Do not braze/solder fittings into head

Never use a saddle valve for connection

OPERATION TIPS

Change cartridges on a regular 6 month preventative maintenance program

Change cartridges when capacity is reached (20,000 gallons) or when flow becomes too slow

Change cartridges when the difference between the two pressure gauges is greater than or equal to 20 psi

Service flow rate must not exceed 5.0 gpm

After installing CC1E cartridge, flush at full flow for 5 minutes. Install CC3E cartridge and flush system for 10 minutes

APPLICATION/SIZING

For high flow, high volume foodservice applications requiring chloramine reduction

Rated Capacity: 20,000 gallons (75,700L)

Up to 5 gpm (19 Lpm) flow rate

For coffee and ice applications, add scale reduction feeder at outlet of system. Part no. EV9798-45

CB20-302E Water Filter

SPECIFICATIONS

Overall Dimensions:
27.75"H x 20.75"W x 9.0"D

Inlet connection:
3/4" FNPT

Outlet connection:
3/4" FNPT

Service Flow Rate:
Maximum 5.0 gpm (19 Lpm)

Rated Capacity: 20,000 gallons (75,700L)

Pressure Requirements:
20 - 100 psi (1.4 - 6.9 bar), non-shock

Temperature:
35 - 100°F (2 - 38°C)

No electrical connection required

Shipping Weight: 46 lbs.

The contaminants or other substances removed or reduced by this drinking water system are not necessarily in your water. Do not use with water that is microbiologically unsafe or of unknown quality without adequate disinfection before or after the system.

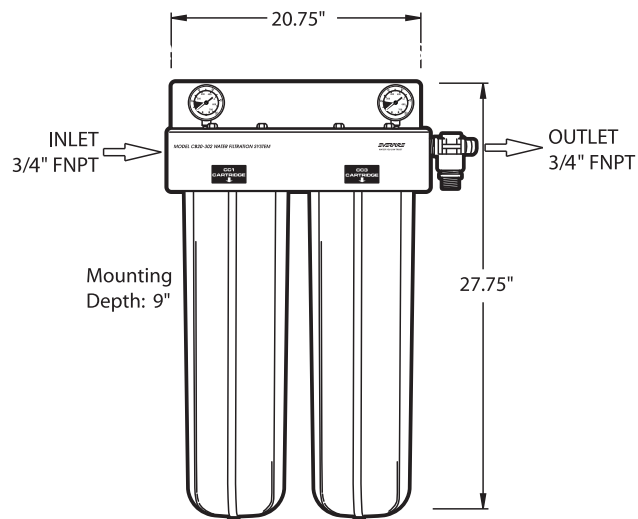

WARRANTY

Everpure water treatment systems (excluding replaceable elements) are covered by a limited warranty against defects in material and workmanship for a period of five years after date of purchase. Everpure replaceable elements (filter cartridges and water treatment cartridges) are covered by a limited warranty against defects in material and workmanship for a period of one year after date of purchase. See printed warranty for details. Everpure will provide a copy of the warranty upon request.

EVERPURE®

Worldwide Headquarters:
EVERPURE, LLC
1040 Muirfield Drive
Hanover Park, Illinois 60133
Toll Free (800) 323-7873
Tel (630) 307-3000
Fax (630) 307-3030
<http://www.everpure.com>

In Europe:
Pentair Water Belgium B.V./B.A.
Industriepark Wolfstee
Toekomstlaan 30
B-2200 Herentals
BELGIUM
TEL: +32.(0).14.283.500
FAX: +32.(0).14.283.505

In Japan:
Hashimoto MN Bldg. 7F
3-25-1 Hashimoto Sagamihara-Shi
Kanagawa 229-1103
JAPAN
TEL: 81.(0)42.775.3011
FAX: 81.(0)42.775.3015