

GUARDIAN™

ULTRAVIOLET MONITOR



**Digital Direct
Mount Monitor**



30-1060B
Standard Probe



**Digital Remote
Mount Monitor**

30-8235B
Remote Probe

35-2049
Remote Cable

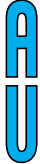
 SINCE 1963
ATLANTIC ULTRAVIOLET
CORPORATION®

Manufacturers / Engineers / Sales / Service
Germicidal Ultraviolet - Equipment & Lamps

375 Marcus Boulevard • Hauppauge, NY 11788
631.273.0500 • Fax: 631.273.0771
Email: Sales@AtlanticUV.com
Ultraviolet.com • BuyUltraviolet.com

Extensive Product Information Available at:

Ultraviolet.com
BuyUltraviolet.com



Installation, Operation & Maintenance

**Read and Follow
All Safety Instructions.
Save these Instructions.**

Owner's Manual

TABLE OF CONTENTS

SAFETY WARNINGS	3
SAFETY INSTRUCTIONS	3
SAFETY LABELS	3
CAUTION.....	3
PRODUCT APPLICATION	4-5
CONSTRUCTION.....	5
PRINCIPLE OF OPERATION	5
LIMITATION OF USE.....	5
UNPACKING.....	5
INSTALLATION	6-8
LOCATION	6
CONVENTIONAL INSTALLATION.....	6-8
TRIP SET POINT	8
INTERNAL AUDIO ALARM	9
SOLENOID	9
SWITCH SETTINGS	9
4 POSSIBLE SWITCH SETTINGS	9
OUTPUTS	10-11
DIGITAL GUARDIAN™ REMOTE MONITOR RJ45	10
4-20mA OUTPUT.....	11
DRY CONTACTS.....	11
REMOTE LOW VOLTAGE.....	11
TROUBLESHOOTING	12-14
“LOW” INTENSITY READING	12
TECHNICAL SPECIFICATIONS	14
OPTIONAL ACCESSORIES	14
MAINTENANCE NOTES	15
USER ASSISTANCE	16
PRODUCT REGISTRATION	16
WARRANTY	16
PATENT NOTICE.....	16

These instructions generally describe the installation and operation of the **GUARDIAN™** Ultraviolet Monitor. Questions that are not specifically answered by these instructions should be directed to the Factory. Atlantic Ultraviolet Corporation® takes all possible precautions when packaging equipment to prevent damage. Carefully inspect and report all damages. Do not install damaged equipment. Follow all instructions on any labels or tags. Carefully inspect all packing materials before discarding to prevent the loss of accessories, mounting hardware, spare parts or instructions.

The information and recommendations contained in this publication are based upon data collected by the Atlantic Ultraviolet Corporation® and are believed to be correct. However, no guarantee or warranty of any kind, expressed or implied, is made with respect to the information contained herein. Specifications and information are subject to change without notice.

SAFETY WARNINGS

- All personnel should be alerted to the potential hazards indicated by the product safety labeling on this unit.
- The following conventions are used to indicate and classify precautions in this manual and on product safety labeling. Failure to observe precautions could result in injury to people or damage to property.

 This is the safety alert symbol. It is used to alert you to potential personal injury hazards. Obey all safety messages that follow this symbol to avoid possible injury or death.

⚠ DANGER Danger indicates an **IMMINENTLY** hazardous situation, which, if not avoided, **WILL** result in death or serious injury.

⚠ WARNING Warning indicates a **POTENTIALLY** hazardous situation, which, if not avoided, **COULD** result in death or serious injury.

⚠ CAUTION Caution indicates a **POTENTIALLY** hazardous situation, which, if not avoided, **MAY** result in minor or moderate injury.

CAUTION Caution used without the safety alert symbol indicates a potentially hazardous situation, which, if not avoided, may result in property damage.

 This symbol/pictorial is used to identify an **ELECTRICAL SHOCK** or **ELECTROCUTION** hazard.

 This symbol/pictorial is used to identify an **ULTRAVIOLET LIGHT** hazard.

 This symbol/pictorial is used to identify the need to wear approved ultraviolet blocking eye-wear.

 This symbol/pictorial is used to identify the need to wear approved ultraviolet blocking face shield.



 This symbol/pictorial is used to identify the need to wear protective gloves.





 This symbol/pictorial is used to identify components which must not be disposed of in trash

SAFETY INSTRUCTIONS

⚠ WARNING To guard against injury, basic safety precautions should be observed, including the following:

1. Read and follow ALL safety instructions.

   **⚠ WARNING** Avoid exposure to direct or reflected germicidal ultraviolet rays. Germicidal ultraviolet rays are harmful to the eyes and skin.

2. Intended for indoor use only.
3. Do not alter design or construction.
4. Do not use this unit for anything other than its intended purpose, as described in this manual.
5. Do not remove any labels or devices.
6.  The **GUARDIAN™** Ultraviolet Monitor should be protected from harsh environments, high humidity, and temperature extremes.
7.  **⚠ WARNING** The **GUARDIAN™** Ultraviolet Monitor housing is **not waterproof**. Serious damage can occur if internal electronics come in contact with water.
8.  **⚠ CAUTION** Germicidal ultraviolet rays may break down plastic, rubber or other non-metallic materials, with inadequate resistance to ultraviolet. Shield all plastic, rubber or other non-metallic parts such as: plastic drain pans, wire insulation, flex ducts, humidifiers, filters, etc. which may be exposed to direct or reflected germicidal ultraviolet rays.
9. Do not operate the **GUARDIAN™** Ultraviolet Monitor if the power cord and/or plug are damaged, or if any other damage to the monitor is visible or suspected.
10.  **⚠ WARNING** Do not operate without proper electrical ground.
11. Utility power supplied, to the **GUARDIAN™** Ultraviolet Monitor, **MUST** match power requirements listed on the monitor label.
12.  **⚠ WARNING** Always disconnect power, to the **GUARDIAN™** Ultraviolet Monitor and unplug, before performing any service or maintenance
13. Read and follow all notices and warnings on the unit.
14. **SAVE THESE INSTRUCTIONS.**

SAFETY LABELS

Warnings on 2 sides of each monitor

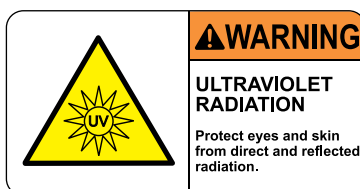

Warning Label: Ultraviolet Radiation (00-0195A2)



Location of Warning Label (00-0195A2)

CAUTION

It is the user's responsibility to determine and validate the suitability of this equipment for use in the user's system or process. No warranty or representation is made by the manufacturer with respect to suitability or performance of this equipment or to the results that may be expected from its use.

The user should periodically inspect, clean as necessary and confirm the presence and good legibility of the product safety labels. Contact the factory for replacement labels in the event that any of the labels are missing or illegible.

PRODUCT APPLICATION

Figure 1 – Digital GUARDIAN™ Monitor Face



Figure 2 – Rear View of Digital GUARDIAN™

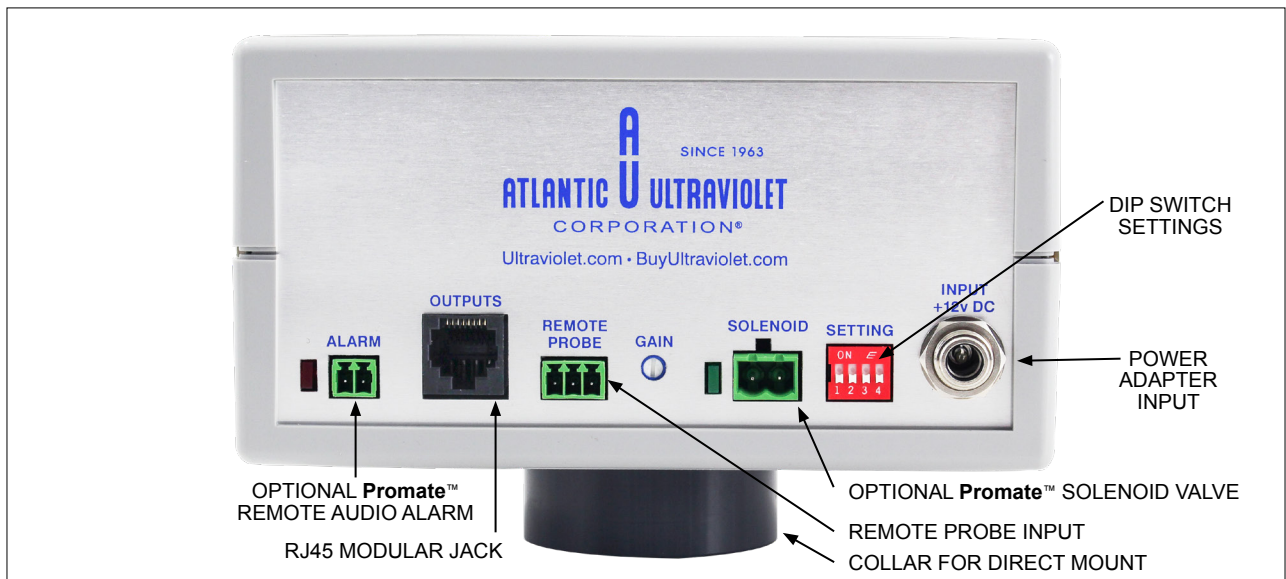

Figure 3 – Standard Probe



Figure 4 – 110/220v Power Adapter



Figure 5 – 12v Power Adapter



Figure 6 – Remote Probe



PRODUCT APPLICATION CONT.

CONSTRUCTION

- Each **GUARDIAN™** is accompanied with a high quality, precisely machined Sensor Probe made from Stainless Steel Type 316 which contains a highly polished quartz optical rod. Two types of Sensor Probes are available, the Standard Sensor Probe (See Figure 3) and the Remote Sensor Probe (See Figure 6). Sensor Probes are installed directly to a purifier by means of a Sensor Probe Fitting also known as a Sight Port Fitting.
- The **GUARDIAN™** Ultraviolet Monitor is designed to mount directly to the Sensor Probe on the purifier, or in the case of a Remote **GUARDIAN™**, near the unit with a provided cable between the Remote Sensor Probe and the **GUARDIAN™**.
- The **GUARDIAN™** is fabricated from UL Approved ABS Fire Retardant Plastic with a clearly marked silk screened anodized aluminum instrument face to ensure long life and resistance to corrosion and wear.

PRINCIPLE OF OPERATION

The **GUARDIAN™** Ultraviolet Monitor visually indicates the level of germicidal ultraviolet energy that penetrates the quartz sleeve and liquid within the purifier. The monitor will detect reduction of ultraviolet levels due to:

- Fouling or deposits on the quartz sleeve.
- Fouling or deposits on the face of the sensor probe quartz rod.
- Poor ultraviolet transmission through the liquid. **Note that color, turbidity, and organic or other impurities in the liquid can reduce or interfere with the transmission of ultraviolet rays.**
- Lamp outage, or depreciation of the lamp output. **Note that germicidal ultraviolet lamp output gradually depreciates with use.**

When the **GUARDIAN™** Ultraviolet Monitor detects a germicidal ultraviolet energy level which is acceptable, it will:

- Light a Green LED on the front of the instrument panel with the heading “**NORMAL**”
- Provide output power to the connector with the heading “**SOLENOID.**” If an optional **Promate™** Solenoid Valve is present in your plumbing circuit and connected to this output, the **Promate™** Solenoid Valve will continue to allow water to flow through your purifier.
- Display should read between 30 and 120.

When the **GUARDIAN™** Ultraviolet Monitor detects a germicidal ultraviolet energy level which is unacceptable it will:

- Light a Red LED on the front of the instrument panel with the heading “**LOW**”
- Sound Internal Audio Alarm. Internal Audio Alarm can be disabled by the switch setting on the rear panel. (See **Switch Settings on Page 9.**)
- Provide output power to an optional external **Promate™** Remote AUDIO ALARM.
- If an Optional **Promate™** Solenoid Valve is present in your plumbing circuit and connected to the “**SOLENIOD**” output, the **Promate™** Solenoid Valve will de-energize and stop the flow of water flow through your purifier. **GUARDIAN™** Monitor LED Display should display a number lower than 30.

LIMITATION OF USE

The **GUARDIAN™** Ultraviolet Monitors are intended to be used on the **SANITRON®** and **MIGHTY★PURE®** Ultraviolet Water Purifiers or other models made specifically by Atlantic Ultraviolet Corporation®. Using this monitor on any other product not recommended or recognized by Atlantic Ultraviolet Corporation® may result in a false sense of security and can lead to improperly treated water or other liquids.

UNPACKING

- Remove the **GUARDIAN™** Ultraviolet Monitor, Power Adapter, Sensor Probe and Allen Wrench from its shipping carton.
- Atlantic Ultraviolet Corporation® takes all possible precautions when packing this unit to prevent damage. Carefully inspect the unit as well as the sensor probe and other contents of the carton for damage. Report all damage immediately. Do not assemble or operate if there is any damage.
- Carefully inspect all packing materials to prevent the loss of accessories, spare parts, or instructions.
- Do not discard packing materials until unit is assembled, checked and confirmed in working order.

INSTALLATION

LOCATION

- The **GUARDIAN™** Ultraviolet Monitor is intended for indoor use only. Sensor Probes are installed directly to a purifier by means of a Sensor Probe Fitting, also known as a Sight Port Fitting. The **GUARDIAN™** Ultraviolet Monitor should be protected from environments, high humidity, and temperature extremes or dripping water.
- Electrical power is supplied to the **GUARDIAN™** Ultraviolet Monitor by a 110/220v or 12v DC Power Adapter (See **Figure 4** and **Figure 5**).

CONVENTIONAL INSTALLATION (SEE FIGURE 9 FOR EXAMPLE OF CONVENTIONAL INSTALLATION)



IN ORDER TO PERFORM THIS TASK, BE SURE TO WEAR THE FOLLOWING SAFETY EQUIPMENT: SAFETY GLASSES OR A FACE SHIELD, AS WELL AS GLOVES.

⚠ WARNING Always disconnect power to all devices before performing any service or maintenance.

- Each monitor is calibrated with its accompanying sensor probe. The serial number engraved on the sensor probe must match the serial number of the monitor. If installing more than one monitor, **DO NOT** interchange sensor probes.
- Newer **GUARDIAN™** monitors have been calibrated for use with updated sensor probes and cannot be used with earlier model probes without factory recalibration.
- Older model water purifiers may require a reducing bushing to properly mount the newer sensor probes. If you are unsure whether the reducing bushing is required, contact the factory.

Figure 7 – Removal of Sight Port Plug



Figure 8 – Installing a Standard Probe into Sight Port Fitting

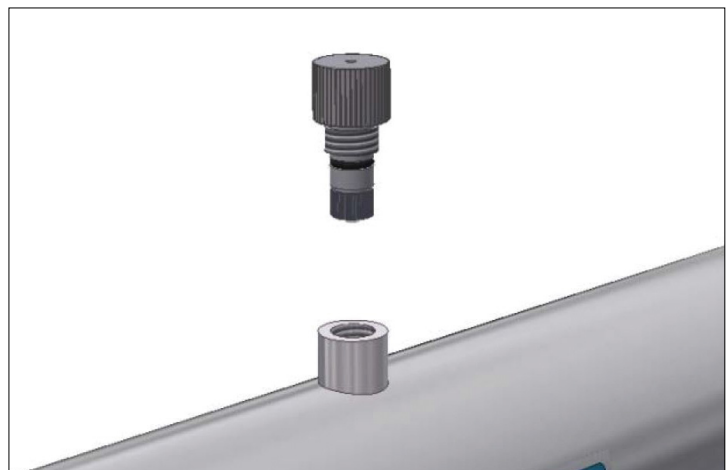

Figure 9 – Mounting the Monitor on the Probe



1. **⚠ WARNING** Unplug the water purifier from electrical outlet.
2. If the purifier has been in service, shut off water supply to the purifier via the inlet and outlet shut off valves. Drain some water from tank.
3. Remove the translucent sight port plug from the center sight port fitting of the chamber. (See **Figure 7**)
4. Insert Sensor Probe into the center Sight Port Fitting of the purifier chamber and tighten securely. The use of thread sealing tape, sealing compounds, or hand tools for tightening are not required. Note that a Standard Probe is being installed and that the Remote Probe would be installed in the same manner. (See **Figure 8**)

CAUTION The quartz rod protrudes out past the probe cap, be careful not to strike rod against fitting when installing the probe.

CONVENTIONAL INSTALLATION CONT. (SEE FIGURE 9 FOR EXAMPLE OF CONVENTIONAL INSTALLATION)

5. Slowly restore water supply to the water purifier, pressurize (keeping outlet valve closed), and check for leaks. Once it is determined that there are no leaks, the inlet valve can be fully opened.
6. Mount the **GUARDIAN™** Ultraviolet Monitor on top of the Sensor Probe; position the monitor as desired, and secure by tightening the set screws in the collar using the supplied 5/64" Allen Wrench. (See **Figure 9**)
7. Any optional accessories such as, **Promate™** Solenoid Valve, Remote Cable, or Digital Output Cable can now be connected to the appropriate connectors on the rear of the monitor. (See **Figure 2**)
8. With the monitor switch in the "OFF" position, connect power adapter to cable connection on rear of unit labeled "Input 12v DC" then plug the power adapter into an electrical outlet.
9. Plug the water purifier into electrical outlet and restore power. Allow purifier to warm up for approximately 10 minutes. Warm up period allows germicidal lamp to reach full output.
10. Switch the monitor "ON". The **Promate™** Solenoid Valve (if installed) should open and the "NORMAL" indicator light should come on. Digital meter should read between 30 and 120.
11. Open outlet valve.
 - If, for any reason, the ultraviolet intensity falls to an inadequate level (generally less than 30 on the meter), the "LOW" indicator LED will light, the **Promate™** Audio Alarm (if Activated) will sound, and the optional **Promate™** Solenoid Valve (if installed) will close.

Figure 10 – Example of a Standard Installation

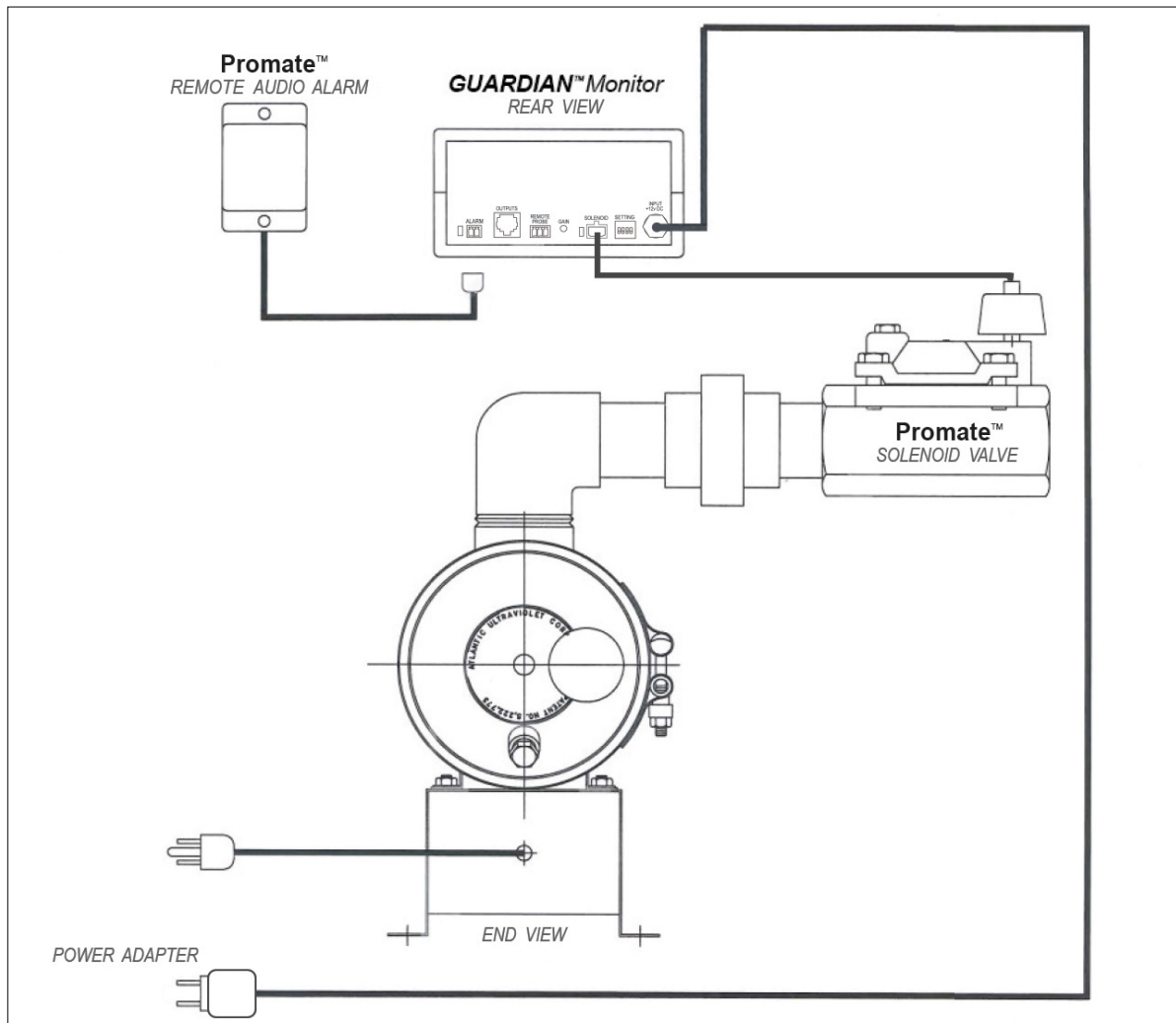

INTERNAL AUDIO ALARM

When the lamp intensity reaches the lower trip point, the internal audio alarm will sound. This can be enabled or disabled by the switch settings. (See Switch Settings Below)

SOLENOID

When lamp intensity rises above the set trip point, the Solenoid Output will energize the optional **Promate™** Solenoid Valve, allowing water to flow. When lamp intensity falls below the set trip point, the **Promate™** Solenoid Valve will close and the water flow will stop. The Solenoid Output can be set for two-minute delay at start-up to allow the lamps time to reach full intensity. (See Switch Settings Below)

SWITCH SETTINGS

4 POSSIBLE SWITCH SETTINGS (SEE BELOW)

Setting 1

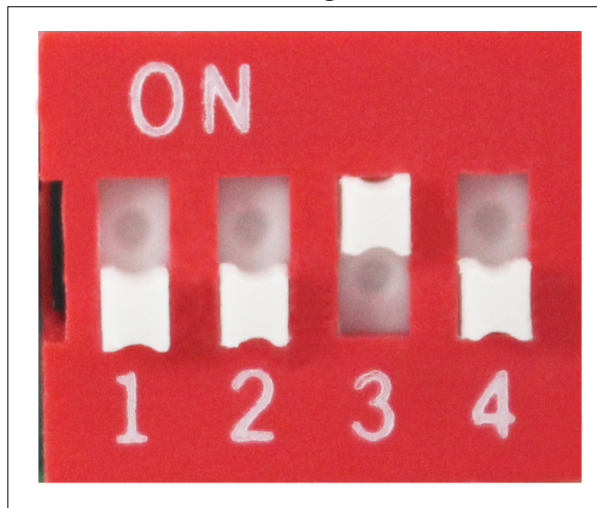

Normal Operation
No Internal Audio Alarm

Setting 2

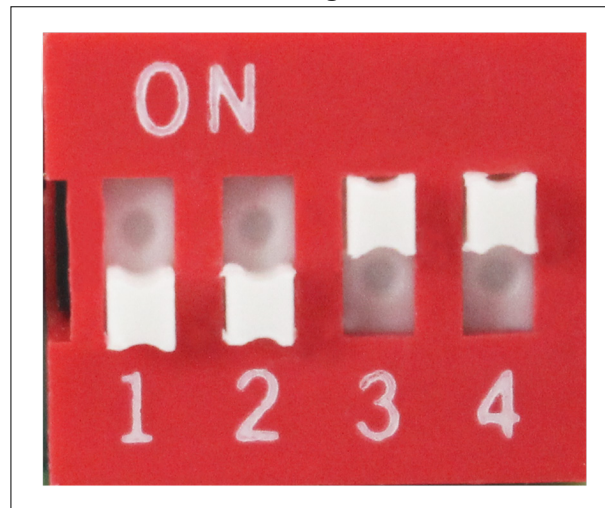

Normal Operation
with Internal Audio Alarm

Setting 3

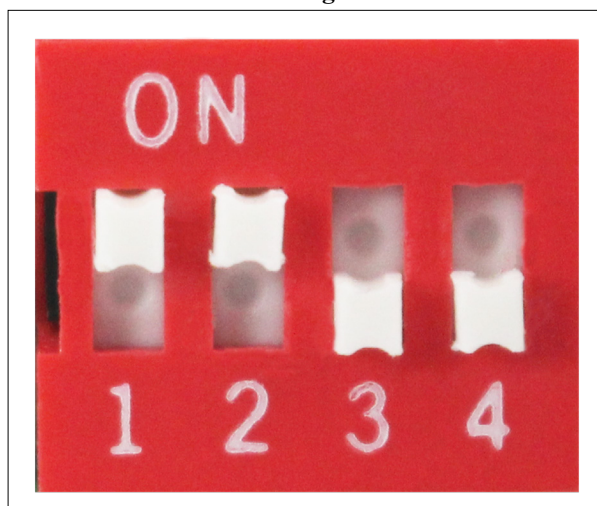

2-Minute Delay
No Internal Audio Alarm

Setting 4

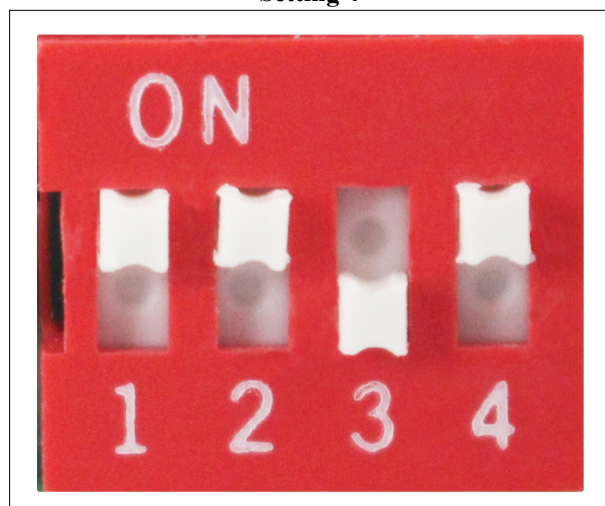

2-Minute Delay
with Internal Audio Alarm

OUTPUTS

DIGITAL GUARDIAN™ MONITORS MODULAR REMOTE OPTIONS

The digital **GUARDIAN™** Ultraviolet Monitors are capable of supplying outputs for remote monitoring of the water purifiers operation. An RJ45 connector, located on the back of the **GUARDIAN™** Ultraviolet Monitor, is provided to access these outputs (See Figure 2). An RJ45 cable is required to interconnect between the **GUARDIAN™** and the remote monitoring devices. An RJ45 modular jack adapter might be need to interconnect the RJ45 cable and a remote monitoring device. The RJ45 cable and modular jack adapter are not supplied and can be obtained from the factory. See “**Promate™** Optional Accessories” or contact the factory with specific requirements..

Table 1 – Digital GUARDIAN™ Modular Remote Options Connection

Wire No.	Application	Modular Jack Wire Color	Modular Network Cable Wire Color
1	External Power 4-20 MA	Blue	White/Orange
2	Dry Contact - Normally Closed (NC)(UV “Normal”) A	Orange	Orange
3	Output Current/Low-Voltage Audio Alarm-Common Negative	Black	White/Green
4	Dry Contact-Common	Red	Blue
5	Output Current - 4-20mA(+)	Green	White/Blue
6	Dry Contact - Normally Open (NO)(UV “NORMAL”) A	Yellow	Green
7	Low-Voltage Audio Alarm - +12v (UV “NORMAL”) A	Brown	White/Brown
8	Low-Voltage Audio Alarm - +12v (UV “LOW”) B	White	Brown

A. UV “**NORMAL**”: Ultraviolet lamp operating, ultraviolet intensity above trip set point and “**NORMAL**” indicator light, lit.

B. UV “**LOW**”: Ultraviolet lamp may or may not be operating, ultraviolet intensity below trip set point and “**LOW**” indicator light, lit.

Figure 12 – Digital GUARDIAN™ Modular Remote Options Connection

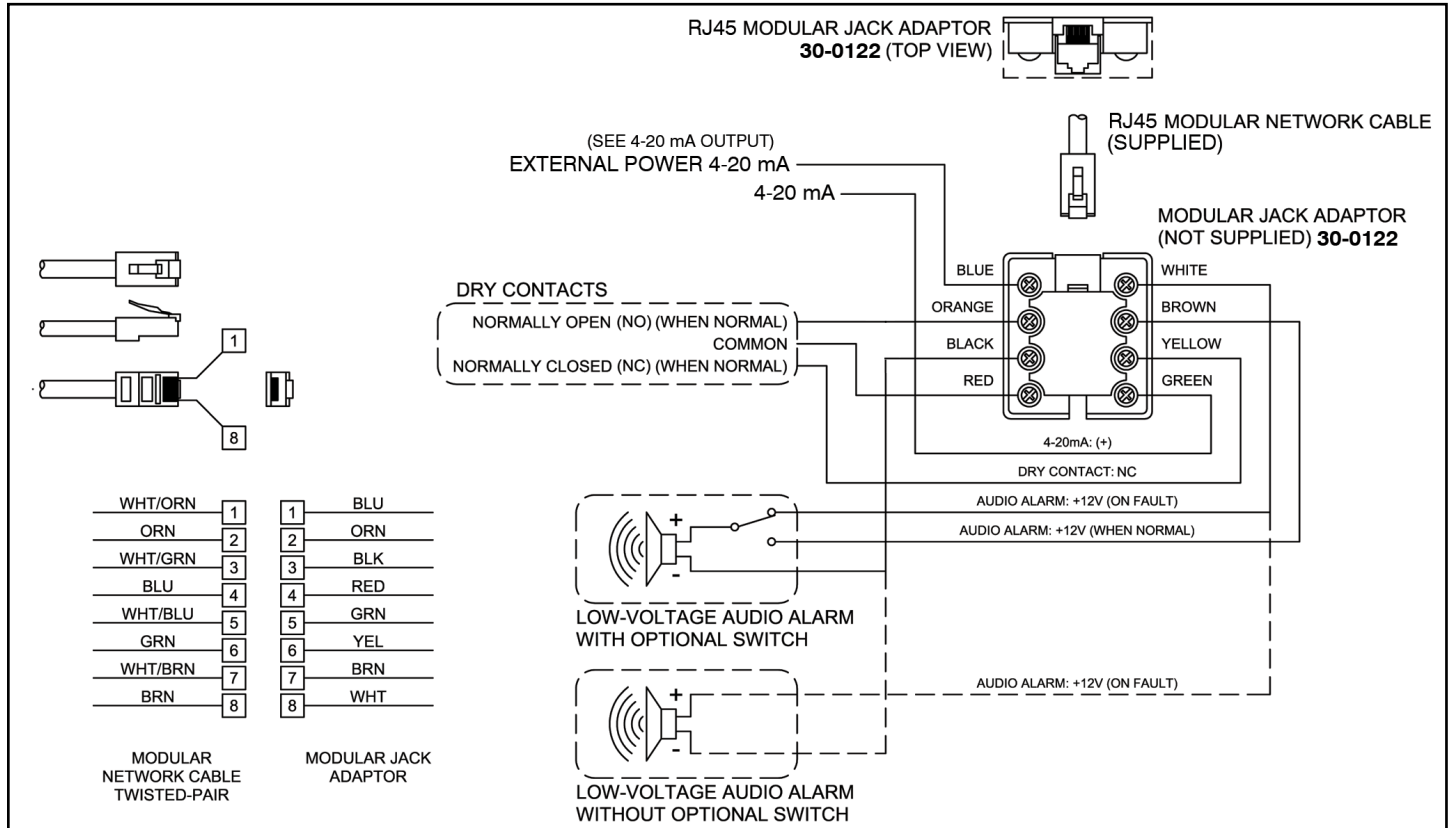

OUTPUTS CONT.

AVAILABLE OUTPUTS DIGITAL GUARDIAN™ REMOTE MONITOR RJ45 CONNECTOR

4-20mA OUTPUT

The 4-20mA output supplies an output corresponding to the intensity meter, converted to a current between 4 and 20mA. The output is unaffected by reasonable line resistances, but the output must be displayed by a PLC, computer, or 4-20mA meter which can interpret the signal. A 4mA output will be displayed as 0% ultraviolet intensity and 20mA will be displayed as 120%.

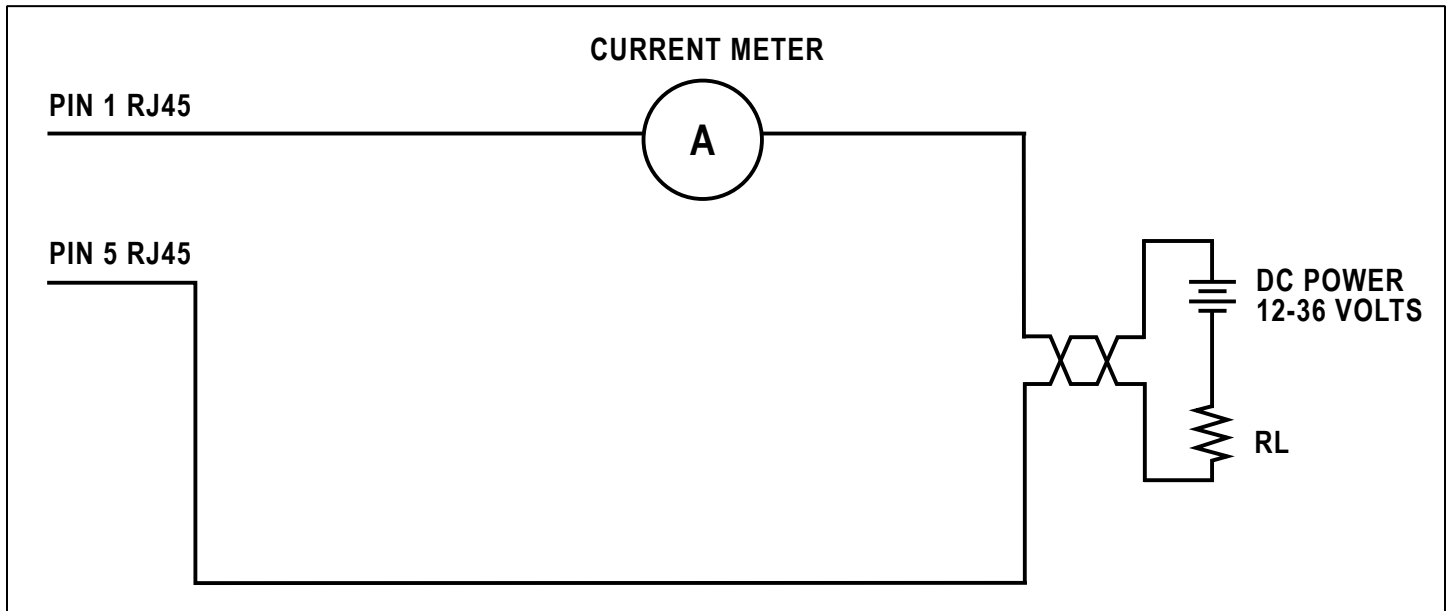

DRY CONTACTS

The Dry Contact output provides a Single Pole Double Throw (SPDT) output corresponding to the “NORMAL” or “LOW” intensity of the germicidal lamp. The contacts are rated at 50v 100mA maximum.

- “Common” will connect to “Pin 2” when the display value is above the trip set point and the green “NORMAL” indicator LED is lit.
- “Common” will connect to “Pin 6” when the display value is below the trip set point and the red “LOW” indicator LED is lit.

REMOTE LOW-VOLTAGE PROMATE™ AUDIO ALARM

A 12v DC 100mA maximum output is provided to power a remote low-voltage audio alarm. An optional Single Pole Double Throw (SPDT) switch can be installed with the low-voltage Promate™ Audio Alarm in a way that allows the audio alarm to be silenced during an alarm condition. The audio alarm will sound again when the normal condition is restored; this prevents the alarm from being accidentally disabled by the switch.

TROUBLESHOOTING

“LOW” INTENSITY READINGS

If, during the normal operation of the purifier, the intensity readings fall to an inadequate “LOW” level, take the following steps:

Verify Lamp Life

1. **STER-L-RAY**® Lamp Replacement is recommended every 10,000 hours of operation, which is approximately 12 months of continuous service. Verify that your **STER-L-RAY**® lamp has less than 10,000 hours of use on it.
2. Replace **STER-L-RAY**® ultraviolet lamp in your water purifier with a new one or exchange the current ultraviolet lamp in your water purifier with a known good lamp. Follow instructions on how this task is performed in your Water Purifiers Owner’s Manual. If after performing this task, no improvement in the intensity reading is achieved, continue following the “Troubleshooting” Section of this manual.

Clean Quartz Sleeve in Water Purifier

1. Clean the **CRYSTAL CLEAR**™ quartz sleeve; see the Owner’s Manual supplied with the water purifier for the proper cleaning method, and note whether the intensity reading improves.
2. If, after cleaning the **CRYSTAL CLEAR**™ quartz sleeve, there is no significant improvement in the intensity readings, it may be necessary to clean the quartz rod in the sensor probe; continue following the “Troubleshooting” Section of this manual to clean the sensor probe quartz rod.

Cleaning the Sensor Probe

The Sensor Probe contains a small quartz rod which allows the UV rays from the lamp into the **GUARDIAN**™ Ultraviolet Monitor. After a period of time, dirt or sediment built up on the end of the quartz rod can stop the UV rays from passing into the ultraviolet monitor. Follow this section to clean the quartz rod in your sensor probe.



IN ORDER TO PERFORM THIS TASK, BE SURE TO WEAR THE FOLLOWING SAFETY EQUIPMENT: SAFETY GLASSES OR A FACE SHIELD, AS WELL AS GLOVES.

As a precaution, consult your Owner’s Manual supplied with the water purifier to properly disconnect all power to your purifier and stop all water flow into and out of the unit before proceeding to the next step.

⚠ WARNING Disconnect power to water purifier.

⚠ WARNING Germicidal ultraviolet rays are harmful to eyes and skin. **DO NOT** look directly at the germicidal lamp.

1. Shut off water supply to the water purifier via the inlet and outlet shut off valves. Remove drain fitting and drain the chamber. Once the chamber is drained, remove any old sealing tape from the threads of the drain plug, re-wrap with 1/2” wide Teflon® thread sealing tape, reinstall and tighten the drain plug.
2. Disconnect power to the **GUARDIAN**™ Ultraviolet Monitor; remove from chamber by loosening the two set screws on the plastic collar and lifting it free from probe body. (See Figure 9)
3. Unscrew the sensor probe by hand and remove from the chamber. (See Figure 8) . ***NOTE: It is recommended, when servicing the sensor probe, to work in a clean, dry area.**
4. Take care not to damage the quartz rod, O-Ring, or the threads of the probe body. Once the sensor probe has been removed from the purifier, inspect the end of the probe where the quartz rod protrudes from the end cap. Make sure the quartz rod has not been damaged. Clean the end of the quartz rod with alcohol or a mild detergent, and rinse with clean water. Stubborn stains usually can be removed with a dilute hydrochloric acid. Make sure the end face is completely clear and free of all deposits.

⚠ WARNING ***NOTE: Follow all manufacturer’s instructions and precautions when handling chemicals.**

5. After cleaning, inspect the sensor probe, by making sure you can see directly down through the quartz rod to the other side. If it appears the top of the probe is also dirty follow steps (7,8&9) to clean the whole quartz rod. If all appears clean, skip to **Step 10**.
6. In order to clean the whole quartz rod, you must remove the quartz rod from the sensor probe. **Upon disassembly, it is highly recommended to change the O-Ring which seals the end of the quartz rod between the probe cap and probe body. Contact Factory for Part Number and pricing.**
7. Remove the quartz rod sensor probe cap from the probe body. Take care not to damage the quartz rod, O-Ring or the threads of the probe body. (See Figure 12 and Figure 13) ***NOTE: It is recommended, when servicing the sensor probe, to work in a clean, dry area.**

TROUBLESHOOTING CONT.

- Once the quartz rod is removed, clean with alcohol or a mild detergent, and rinse with clean water. Stubborn stains usually can be removed with a dilute hydrochloric acid. Make sure both end faces are complete clear and free of all deposits. ***NOTE: Follow all manufacturer's instructions and precautions when handling chemicals.** Once the quartz rod has been cleaned, handle the rod by the sides to avoid getting fingerprints on the quartz rod faces.
- Clean the probe body by removing any dirt or deposits on all surfaces. The two outside O-Rings should be inspected and can be replaced if worn or damaged.

Figure 13 – Removing Quartz Rod from Standard Probe



Figure 14 – Removing Quartz Rod from Remote Probe



- Reassemble all parts, making sure each O-Ring seats correctly in place as it was prior to disassembly. Make sure that the quartz rod is gently seated against the rear of the probe body, then secure the O-Ring in the correct position between probe body and cap and tighten the probe cap by hand only. **DO NOT USE HAND TOOLS.** Tightening with hand tools may damage the quartz rod or O-Ring seal.
- Reinstall sensor probe into the center fitting of the chamber and hand tighten.
- Slowly** restore water supply to the water purifier, pressurize, and check for leaks. Once it is determined that there are no leaks, inlet valve can be fully opened.

TROUBLESHOOTING CONT.

13. Reposition **GUARDIAN™** Ultraviolet Monitor on probe body and tighten set screws.
14. Restore power to the water purifier and **GUARDIAN™** Ultraviolet Monitor. If, after the cleaning of the quartz rod, there is still no significant improvement in the ultraviolet intensity, as shown on the intensity meter, proceed to the “**Troubleshooting**” section of this manual.

Verify Water Quality

 **WARNING** Disconnect power to water purifier and monitor.

1. Shut off water supply to the water purifier via the inlet and outlet shut off valves. Remove drain fitting and drain the chamber. Once the chamber is drained, remove any old sealing tape from the threads of the drain plug. Re-wrap with 1/2” wide Teflon® thread sealing tape. Reinstall and tighten the drain plug.

 **WARNING** Germicidal ultraviolet rays are harmful to eyes and skin. **DO NOT** look directly at the germicidal lamp.

2. With the water purifier empty of water, restore power to the water purifier and **GUARDIAN™** Ultraviolet Monitor. With no water in the purifier check the readings on the ultraviolet monitor. If the intensity readings have now improved, consider having your water’s UV Transmission level re-tested since this may indicate a change in your water quality.
3. If you are still unable to correct the problem of “LOW” intensity reading, consult our technical support staff.

TECHNICAL SPECIFICATIONS

Table 2 – Technical Specifications

	Digital GUARDIAN™ Specifications
Voltage:	Power Adapter 100-240v input 12v 2A output
Frequency:	50/60/Hz (all models)
Case Dimensions:	6" wide x 4" high x 3 3/4" deep
Case Materials:	UL Rated ABS Plastic
Weight:	2lbs (approximate)
Current:(No Load)	12v +/- 10% .150A
Current:(Loaded)	12v +/- 10% 1.2A with Solenoid
Wattage:	2 Watts/15 Watts with Solenoid
4-20mA Output:	External Source 12-36v
Dry Contact Rating:	50 AC or DC. 100mA
Low-Voltage Audio Alarm:	12v DC 50mA

REPLACEMENT PARTS

Table 3 – Replacement Parts

Part Number	Description
15-0039	GUARDIAN™ Quartz Rod & O-Ring Sensor Probe Assembly
35-2049	GUARDIAN™ Remote Probe Cable (5-Conductor, 10 Meters Long, 32.8 ft.)
30-1060B	GUARDIAN™ Standard Probe
30-8235B	GUARDIAN™ Remote Probe
35-2094A6	GUARDIAN™ Power Cable Assembly, SANITRON® S5,000C for Monitor Kit (6 ft.)
35-2094A3	GUARDIAN™ Power Cable Assembly, SANITRON® S5,000C for Monitor Kit (3 ft.)
35-2100	GUARDIAN™ 12v Power Adapter
35-3045	GUARDIAN™ 110/220v Power Adapter

OPTIONAL ACCESSORIES

Table 4 – Optional Accessories

Part Number	Description
30-1014	GUARDIAN™ ASSIST Ultraviolet Monitor Extension
27-3353	Promate™ Solenoid Valve: 3/4" 12v 2-230 PSI Brass / Lead Free / NSF
27-3354	Promate™ Solenoid Valve: 1" 12v 2-230 PSI Brass / Lead Free / NSF
27-3355	Promate™ Solenoid Valve: 1.5" 12v 2-230 PSI Brass / Lead Free / NSF
27-3356	Promate™ Solenoid Valve: 2" 12v 2-230 PSI Nickel Coated Brass
30-0176	RJ45 Modular Cable, 25 foot long, (8-Conductor) with Male RJ45 Connectors Each End
30-0177	RJ45 Modular Cable, 50 foot long, (8-Conductor) with Male RJ45 Connectors Each End
30-0175	RJ45 Modular Cable, 100 foot long, (8-Conductor) with Male RJ45 Connectors Each End
30-0122	RJ45 Modular Jack Adapter (8-Conductor) Surface Mount with terminal screws
30-1074A	Reducing Bushing for Sensor Probe (Includes 00-0282A O-Ring: Reducing Bushing Sensor Probe Buna-N)
35-1879	Female to Male Cord Set, 5 Poles, 10 Meters (Extension for 35-2049)
35-2099	Promate™ Audio Alarm: 12v DC with 25 ft. long lead.

MAINTENANCE NOTES

USER ASSISTANCE

Atlantic Ultraviolet Corporation® makes every effort to ensure that the **GUARDIAN™** Ultraviolet Monitor is a product of superior quality and workmanship. This manual describes the installation, operation, and maintenance of the **GUARDIAN™** Ultraviolet Monitor.

Please read and become familiar with the contents of this manual before installing or using this unit. If after reading the manual you still have questions, or concerns, regarding the installation or use of this unit, contact our offices, weekdays between 8:30 am and 5:00 pm Eastern Time, at:

Atlantic Ultraviolet Corporation®
375 Marcus Boulevard
Hauppauge, New York, 11788
Tel: 631.273.0500
Fax: 631.273.0771
Email: Sales@AtlanticUV.com
Website: Ultraviolet.com
BuyUltraviolet.com

PATENT NOTICE

No attempt has been made to determine the patent status of applications illustrated or described in this publication. Inclusion in this publication of any design or method of use, which may be patented, is not to be construed as promoting or sanctioning unauthorized use.

WARRANTY & PRODUCT REGISTRATION

We warrant this product to the original owner to be free from defects in material and workmanship when installed in accordance with Atlantic Ultraviolet Corporation® specifications for a period of time as follows:

UV Water Purifier Chambers – Type 316 stainless steel chambers will have a Twelve (12) year Limited Warranty on the stainless steel chamber, from the date of original purchase while the Type 304 stainless steel chambers will have a Six (6) year Limited Warranty on the stainless steel chamber.

UV Air Disinfection Housing – Three (3) year Limited Warranty on the metal housing, from the date of original purchase.

Ballasts – Three (3) year Limited Warranty, from the date of original purchase.

UV Lamps, Monitoring Devices, Optional Accessories, and Other Parts – One (1) year Limited Warranty from the date of original purchase.

Within the warranty period we shall repair or replace such products, which are returned to us with shipping charges prepaid and which are determined by us to be defective. This warranty will not apply to any product, which has been subjected to misuse, negligence or accident; or misapplied; or modified; or repaired by unauthorized person; or improperly installed. Warranty will be null and void if any of the product's original labels are removed. This Limited warranty excludes the cost of labor.

The Buyer shall inspect the product promptly after receipt and shall notify us at our main office in writing of claims, including claims of breach of warranty, within thirty (30) days after the Buyer discovers or should have discovered the facts upon which the claim is based. Failure of the Buyer to give written notice of a claim within the time period shall be deemed to be a waiver of such claim.

The provisions of the above warranty are our sole obligation and exclude all other remedies or warranties, expressed or implied, including warranties of merchantability and fitness for a particular purpose, whether or not purposes or specifications are described herein. We further disclaim any responsibility whatsoever to the customer, or to any person for injury to person, damage to, or loss of property or value caused by any product which has been subjected to misuse, negligence, accident; or modified or repaired by unauthorized persons; or improperly installed.

Under no circumstances shall the Company be liable for any incidental, consequential or special damages; losses or expenses arising from the contract for this product, or in connection with the use of, or inability to use, our product for any purpose whatsoever.

Be sure to register your product and validate purchase within 30 days — registration is simple and will take less than 2 minutes to do.

NOTE – failure to register your purchase may jeopardize warranty.

Go to Ultraviolet.com and scroll down to the bottom of the page, under “Trust” click the “Warranty Registration Form”, complete and click “Submit”. Or click on “Warranty Registration PDF” to download the warranty registration card as a PDF, complete and mail to us at 375 Marcus Boulevard, Hauppauge, NY 11788, or simply fax to 631-273-0771. If you prefer to register by phone, please call 631-273-0500 and our customer service staff will be glad to assist you.

For your convenience, record the following information below. The model and serial number can be found on a label located on the **GUARDIAN™** Ultraviolet Monitor. Keep this manual, along with proof of purchase, handy when contacting our offices.

Purchased From:	Date:
Model:	Serial No.: