



EV9272-00

QL3-BH² System

Delivers premium quality water for coffee applications



QL3-BH² System: EV9272-00

BH² Replacement Cartridge: EV9612-50

BENEFITS

Provides clear, fresh, premium quality ingredient water for great tasting coffee and beverages.

New and improved Micro-Pure II media inhibits the growth of bacteria

Everpure's unique filter blend using activated carbon reduces chlorine taste and odor and other offensive contaminants

Saves energy by reducing scale build-up. Proportioned scale inhibitor feed dramatically prevents limescale from forming in brewers.

Engineered to always feed the correct amount of scale inhibitor into each volume of water

Precoat submicron technology reduces dirt and particles as small as 1/2 micron in size and reduces health contaminants such as cysts

Increases holding time of coffee

Sanitary cartridge replacement is simple, quick and clean. Internal filter parts are never exposed to handling or contamination

INSTALLATION TIPS

Never use saddle valve for connection

Use 3/8" water line

Install vertically with cartridge hanging down

Allow 2-1/2" clearance below the cartridge for easy cartridge replacement

Flush BH² cartridge by running water through filter for three minutes at full flow

OPERATION TIPS

Change cartridges on a regular 6 month preventative maintenance program

Change cartridges when capacity is reached or when pressure falls below 10 psi

Service flow rate must not exceed 0.5 gpm

Always flush the filter cartridge at time of installation and cartridge change

APPLICATION/SIZING

For coffee service applications

For low flow, medium volume brewers

Rated Capacity: 3,000 gallons (11,350L) or 6,000 pots

QL3-BH² System

SPECIFICATIONS

Overall Dimensions:
16.5"H x 3.75"W x 4"D

Inlet connection: 3/8"

Outlet connection: 3/8"

Service Flow Rate:
Maximum 0.5 gpm (1.9 Lpm)

Rated Capacity: 3,000 gallons

Pressure Requirements:
10 - 125 psi (0.7 - 8.6 bar), non-shock

Temperature:
35 - 100°F (2 - 38°C)

No electrical connection required

Shipping Weight:
4 lbs.

Operating Weight:
7 lbs.

The contaminants or other substances removed or reduced by this drinking water system are not necessarily in your water. Do not use with water that is microbiologically unsafe or of unknown quality without adequate disinfection before or after the system.

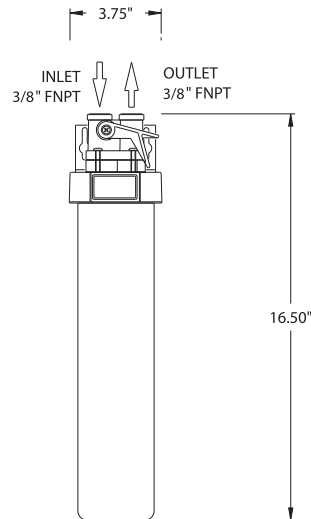

WARRANTY

Everpure water treatment systems (excluding replaceable elements) are covered by a limited warranty against defects in material and workmanship for a period of five years after date of purchase. Everpure replaceable elements (filter cartridges and water treatment cartridges) are covered by a limited warranty against defects in material and workmanship for a period of one year after date of purchase. See printed warranty for details. Everpure will provide a copy of the warranty upon request.

EVERPURE®

Worldwide Headquarters:
EVERPURE, LLC
1040 Muirfield Drive
Hanover Park, Illinois 60133
Toll Free (800) 323-7873
Tel (630) 307-3000
Fax (630) 307-3030
<http://www.everpure.com>

In Europe:
Pentair Water Belgium B.V./B.A.
Industriepark Wolfstee
Toekomstlaan 30
B- 2200 Herentals
BELGIUM
TEL: +32.(0).14.283.500
FAX: +32.(0).14.283.505

In Japan:
Hashimoto MN Bldg. 7F
3-25-1 Hashimoto Sagamihara-Shi
Kanagawa 229-1103
JAPAN
TEL: 81.(0)42.775.3011
FAX: 81.(0)42.775.3015